



we move people



Product overview



Standard product

Mobby-Mover

Standard outfitting

- LiFePO4 battery pack
- Attendants board incl. removable extension
- Electric Link&Go Compatible with all types of Mobby
- 1000 Watt motors

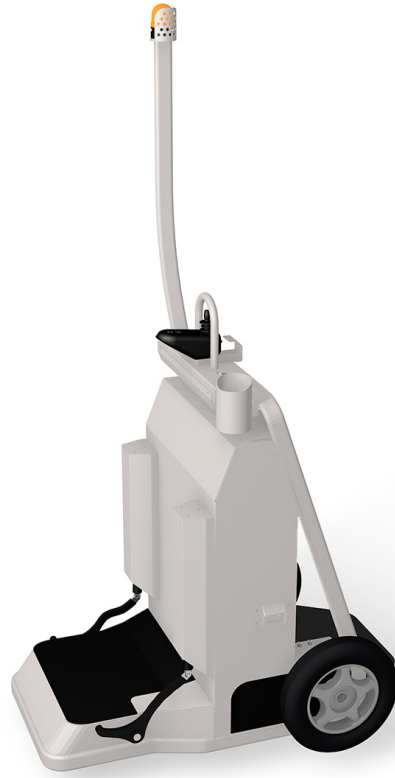

Description

Introducing the Mobby Mover: Your Solution for Safe and Efficient Transport of Mobby's and Beds.

The Mobby Mover is the ultimate solution for streamlining operations, excelling in transporting Mobby's, collecting scattered units, and towing carts, even in narrow hallways and through tight corners. Its multifunctional design even transforms into a bed mover with the optional bed arm, providing invaluable versatility in dynamic environments. With its strength, flexibility, and seamless transportation capabilities, the Mobby Mover ensures efficient and effortless movement, making it an indispensable asset for any healthcare institution.



A general manufacturer's warranty of 2 years applies to our products. The warranty applies to the frame and paintwork and covers any production errors that are reasonably culpable to us.

parts subject to regular wear and tear and damages resulting directly from the regular use of our products or misuse and vandalism will not be covered under warranty.

batteries, wheels, and braking systems are excluded from the warranty at all times.

Customisation options

Mobby-Mover

Options

- Airport Essentials Package
- Dashcam Mobby Mover
- Towbar for Bagage Cart
- Extended attendants board
- Bed transport system (arms)
- AGM Sealed battery pack
(instead of LiFePO4)

Functionalities

Designed to streamline operations, the Mobby Mover excels at transporting Mobby's, collecting scattered units, and towing carts and trolleys with precision. Its multifunctional design extends to cleverly reconfiguring as a bed mover, thanks to the optional bed arm, making it an invaluable asset in dynamic environments.

It also offers the strength and flexibility to pull carts with ease. The small pin beneath the driver platform is used to link food- and linen carts.

Experience seamless transportation solutions with the Mobby Mover.

Technical information

Mobby-Mover

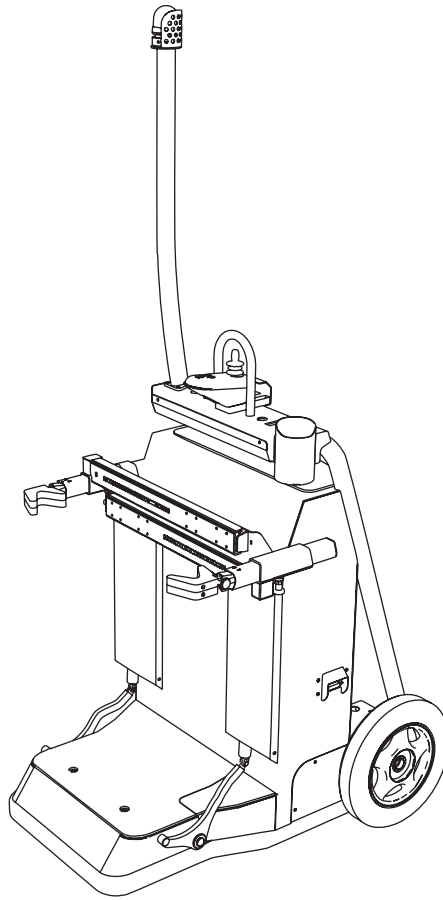

When you hover over a technical specification, you will get a more detailed description here.

Technical specifications

- Weight 195kg with arms, 180kg without
- Overall height 194,3 cm
- Overall length 107 cm
- Overall width 72,4 cm
- 450kg load capacity
- 150kg Link&Go weight capacity
- Puncture proof non-marking tires
- Ground clearance 3,4 cm
- Electromagnetic brake system
- Dynamic (LinX) drive system
- Electric brushed DC-24V 1000W motors (2x)
- Turning circle 107 cm, 360°
- Batteries: standard equipped with 2× AGM lead batteries (160A @ DC-24V), optionally 2× lithium-ion batteries (140A @ DC-24V).
- Charging: on-board charging cablew/ optional regional plug. Power consumption $\pm 720W$ ($\pm 220V * 4A$), max. charging time: 5 hours.
- Standard max. forward speed 8 km/h
- Standard max. backwards speed 2km/h
- Max. slope percentage: 8%

Order process

Mobby-Mover

1. Request an open quote

Request a personalized and obligation-free quote for any products you're interested in.

Fill out [our quick form](#) to get started!



2. Plan a meeting

Use Teams to plan a virtual meeting with our professional sales department.

Schedule your meeting [here](#) and we'll be ready to assist you.



We're here to make every step of your journey with us enjoyable and hassle-free.
If you have any questions, feel free to reach out – we're always happy to help!





Special Mobility BV

Nijverheidsstraat 12a
7041 GE 's-Heerenberg
The Netherlands

Contact us at:



+31 (0)314 - 66 72 10



info@specialmobility.eu



www.specialmobility.eu