



we move people



Product overview



# Standard product

## E-Mobby

### Standard outfitting

- LiFePO4 battery pack
- On board charger
- Armrests and footboard swing-up
- With patented transport fixation
- Steel non padded seating
- 1000 Watt motors
- Choice from our standard colours



### Description

Introducing the e-Mobby: Your Efficient and Ergonomic Solution for Electric PRM Transport.

The e-Mobby redefines electric mobility with its seamless design and versatility. Whether used solo or in combination with Mobby's, it effortlessly transports up to three passengers and luggage at once, offering unmatched convenience.

For enhanced functionality, opt for the electronic linking system to connect Mobby's seamlessly. Experience the future of electric PRM transport with the e-Mobby.



*A general manufacturer's warranty of 2 years applies to our products. The warranty applies to the frame and paintwork and covers any production errors that are reasonably culpable to us.*

*parts subject to regular wear and tear and damages resulting directly from the regular use of our products or misuse and vandalism will not be covered under warranty.*

*batteries, wheels, and braking systems are excluded from the warranty at all times.*

# Customisation options

## E-Mobby

### Options

- Airport Essentials Package  
(including several discounted options)
- Double automatic seatbelt XL
- Luggage rack
- Crutch holder
- Padded comfort seat 5cm
- Padded comfort back 5cm
- Bagholder per piece
- Name / logo plate
- Brakehandle fixation
- Electric Link&Go e-Mobby
- XL seat w/ padded comfort seat
- Dashcam e-Mobby
- Towbar for Bagage Cart
- Extended attendants board
- AGM Sealed battery pack  
(instead of LiFePO4)

### Functionalities

Powered by high-performance motors and equipped with a high-capacity battery pack, the e-Mobby delivers reliable performance with extended range. Dynamic LinX controls enable remote troubleshooting and updates worldwide, ensuring continuous operation.

With onboard charging and comfortable, easy-to-clean seating, the e-Mobby prioritizes passenger comfort and convenience. Safety is paramount, with features including a flashing beacon, acoustic warning signal, horn, emergency stop, and deadman's switch.

# Technical information

## E-Mobby

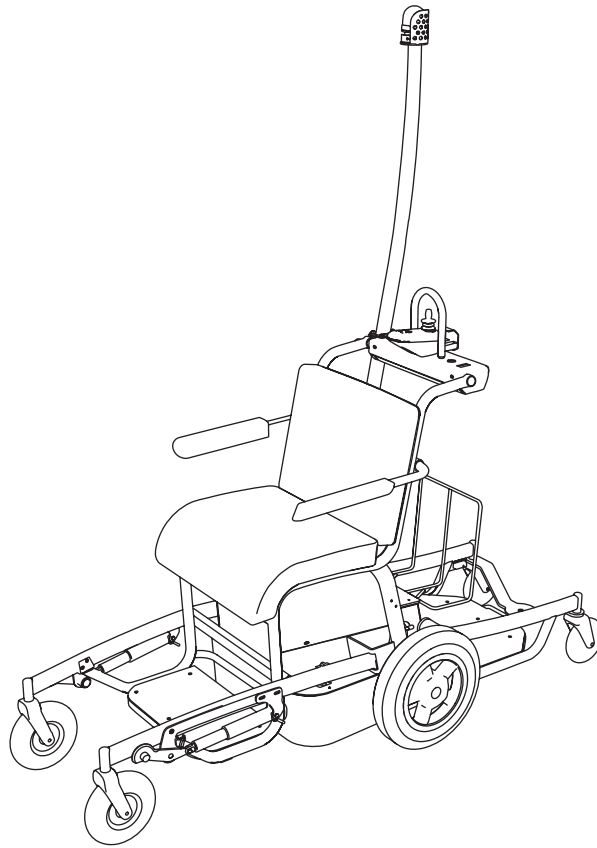

When you hover over a technical specification, you will get a more detailed description here.

## Technical specifications

- Weight 154,6kg
- Overall height 198,9 cm
- Overall length 177,5 cm
- Overall width 70 cm
- 450kg load capacity
- 150kg Link&Go weight capacity
- Puncture proof non-marking tires
- Ground clearance 4,3 cm
- Effective seat depth is 400 mm, effective seat width is 500 mm
- Electromagnetic brake system
- DynamicControls (LinX) drive system
- Electric brushed DC-24V 1000W motors (2x)
- Turning circle 177,5 cm, 360°
- Batteries: standard equipped with 2× AGM lead batteries (85A @ DC-24V), optionally 2× lithium-ion batteries (100A @ DC-24V).
- Charging: on-board charging cable w/ optional regional plug. Power consumption ±880W (±220V \* 4A), max. charging time: 3,5 hours.
- Standard max. forward speed 8 km/h
- Standard max. backwards speed 2km/h
- Max. slope percentage: 8%

# Order process

---

E-Mobby

## 1. Request an open quote

Request a personalized and obligation-free quote for any products you're interested in.

Fill out [our quick form](#) to get started!



## 2. Plan a meeting

Use Teams to plan a virtual meeting with our professional sales department.

Schedule your meeting [here](#) and we'll be ready to assist you.



We're here to make every step of your journey with us enjoyable and hassle-free.  
If you have any questions, feel free to reach out – we're always happy to help!





## Special Mobility BV

Nijverheidsstraat 12a  
7041 GE 's-Heerenberg  
The Netherlands

### Contact us at:



+31 (0)314 - 66 72 10



info@specialmobility.eu



www.specialmobility.eu